

# Prototype PHD & MMP Forced Plane

[www.shwaycoms.com](http://www.shwaycoms.com)

Version 1.7

Estimates for building the attached prototype at convenient metrics of inner shaft diameter for suitable modulated momentum propeller prototype eg: 40 cm diameter rotors and propeller plane. The prototype example item that I am looking to build is PHD & MMP Forced Plane, covering two variants with one prototype model, having variable control motors and suitable psu's in bundle for convenient testing. Propeller plane turbine and propellers should spin at for example upwards of 6,000 rpm on ~1,000w 220V motors all rotors. The construct of the shafts should be carbon fiber material having mount points built in for propeller turbines and propeller plane assemblies. The operating medium is ordinary air at ambient pressure in a sealable cylindrical shaft assembly of shafts.

Rotors should be 40 cm in diameter so an inner shaft at 42 cm ID and outer shaft 64 cm OD. Propellers, carbon fiber, should be 8-blade downwards forcing propellers having inverse opposing rotation orientations for clockwise ( lower ) and counter-clockwise ( upper ) propeller.

Rotor material for a propeller plane assembly is lightweight material, carbon fiber, diameter (40cm)  $r \approx 3\text{cm} \times 20\text{cm} \times 6\text{cm} \times 3.0\text{mm}$ . A propeller plane rotor assembly has 4-blades, 8-blade or 2-blade fallback and should have an outer height of 3 cm, length of 20 cm, inner height of 6 cm and be 3 mm thick.

All motors should have rpm meters fixed to them giving rotation readings and installed pressure sensors where indicated in the figure below. All peripheral wiring and electrics to be included for 3-5 meter distance operation testing.

All 220 V wiring are separated from low voltage sensor wiring; use shielded cables for sensors.

### Prototype configuration :

Shell casing in carbon fiber with 4 mm thick safety walls in case of blade failure at high rpm and sealable closing top using suitable fasteners.

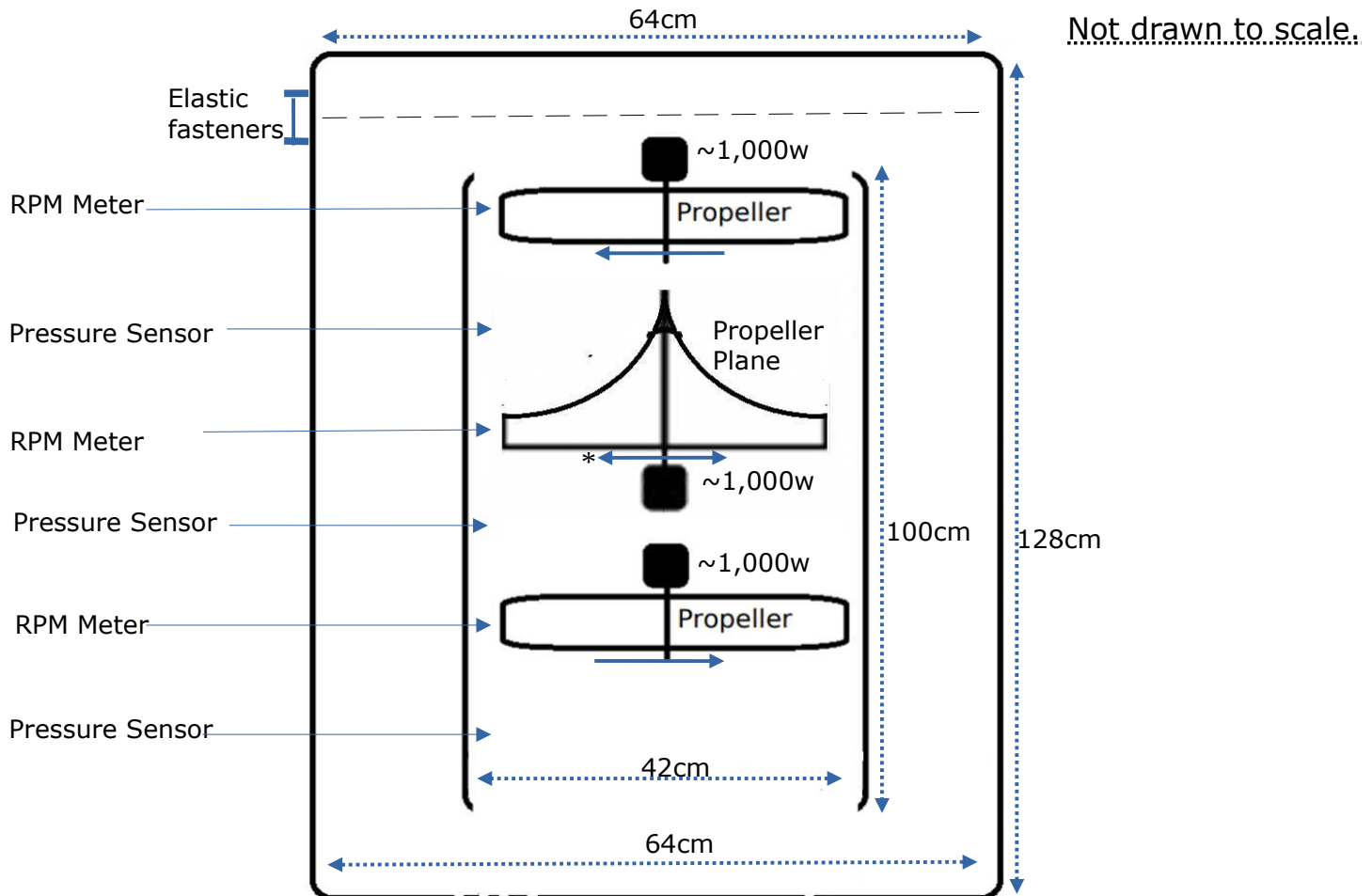

### Metrics :

**Motor specification :** Qiwo Motor Store ~1,000 W high speed BLDC motors with matched 220 V AC drivers, Qiwo Model QW80BL00760-1000, 6,000 rpm rating for propellers and propeller plane with torque  $\geq 1.6\text{N.m}$ , weight  $\leq 3.5\text{ kg}$  and length  $< 20\text{cm}$ .

**Power supply :** A/C 220v 50/60 Hz mains with running current: 4.5–6.5 A each motor to driver BLDC variable control output.

**RPM sensor range :** 0 – 6,000rpm, digital output (pulse per revolution), logged at 100–500 Hz as per Qiwo Hall controller.

### Pressure ranges expected :

MMP  $\pm 200\text{ pa}$  ..  $\pm 400\text{ pa}$  fore / aft of propeller plane in operation.

PHD  $-400\text{ pa}$  ..  $-800\text{ pa}$  aft of propeller plane in operation.

**Pressure sensors :** 2x differential pressure sensors referenced to ambient at  $\leq 5\text{--}10\text{ Pa}$  effective resolution, one tap upstream, one tap downstream, sample rate (to controller): 100–500 Hz, sensor type: differential pressure transducer,

sensor range:  $\pm 5$  kPa ( $\pm 50$  mbar), sensor type: digital bus - I<sup>2</sup>C or SPI digital outputsensor, location: flush to wall, style: short tubing, 1x absolute pressure sensor at bottom position. Rendering platform : [Pressure Sensors] → I<sup>2</sup>C/SPI → [Raspberry Pi] → HDMI → [Raspberry Pi Monitor]

**Cables :** cables can pass through the inner shaft wall ( ducted ) leading to and from motor or sensor to run up the casing of the medium return outer shaft where there is more space available taking care to pressure seal the throughput with a gasket seal.

### Testing :

Test : PHD as well as variant ( ← ←  $r$  ) MMP Forced Plane.

Standard test matrix : propeller plane 2,000 → 3,000 → 4,000 → 5,000 rpm and propellers 2,000 → 3,000 → 4,000 → 5,000 rpm for each rpm step of the propeller plane, in total 32 test sequences for both PHD and MMP, 16 each, log  $\Delta p$ , absolute p, RPM, thrust,  $\Delta p_a$ , absolute p<sub>a</sub>.

Test : 4-blade baseline vs 8-blade high density or 2-blade nominal density propeller plane comparison if the 4-blade plane doesn't perform optimally.

Expected inertial thrust yield : 5–10kg

Prototype weighted down if necessary mounted on a load cell to directly measure 5–10 kg thrust.

### Trouble shooting :

Option replace 4-blade baseline density propeller plane assembly with 8-blade high density model should the module lack performance eg: not providing propulsive support with adequate inertial membrane spread; Nb: a 2-blade nominal density propeller plane assembly may prove optimal being capable of higher in flow rotation speeds for the same torque and having less centripetal blade mass inertial merge with swap out depending on diagnostic from 4-blade tests; for example such as if the 4-blade stalls early not achieving rpm targets due to insufficient torque which may also indicate a higher spec torque motor being needed ie: 3,000 rpm rated for lower rpm, higher torque spec performance at 1,000 W, 4-blade propeller plane moments in faster flow rates stress load on a propeller plane's rotation parameter.

Motor Metrics : Qiwo Model QW80BL00760-1000 220 V 6,000 rpm

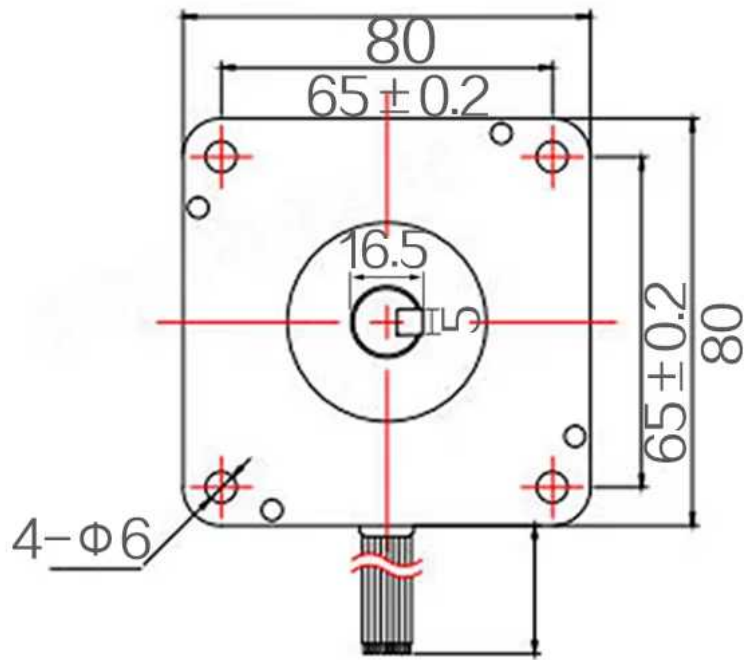
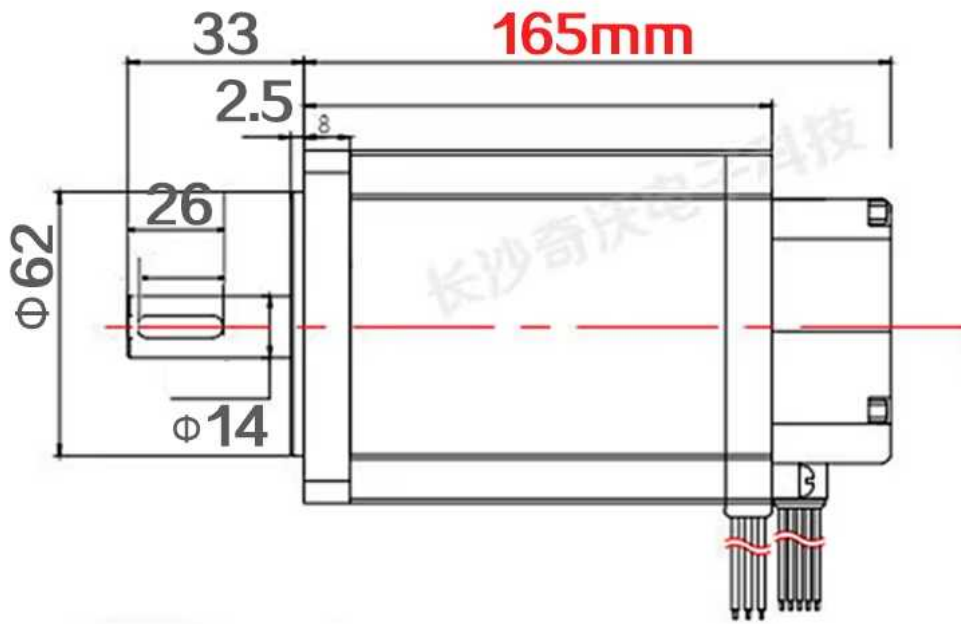

Top view casing :

Shell casing in carbon fiber with 4 mm thick blade failure safety walls

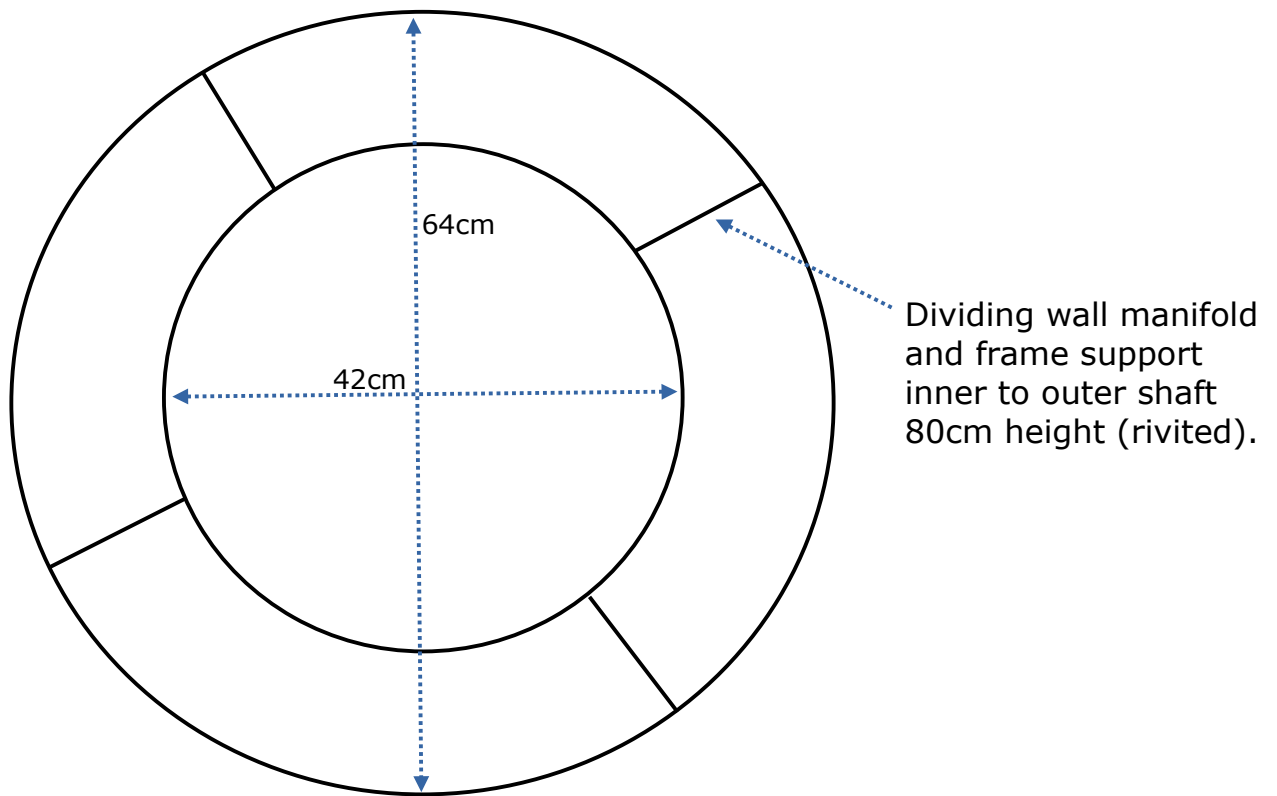

Propeller plane :

Light weight material, carbon fiber, construct having ~1,000w 220V motor as per all 3 turbines exhibited and 4-blade alt. 8-blade or 2-blade model constructs of diameter (40cm)  $r \approx 3\text{cm} \times 20\text{cm} \times 6\text{cm} \times 3.0\text{mm}$ . The propeller plane assembly is positioned at an equal distance length from fore and aft propeller turbines.

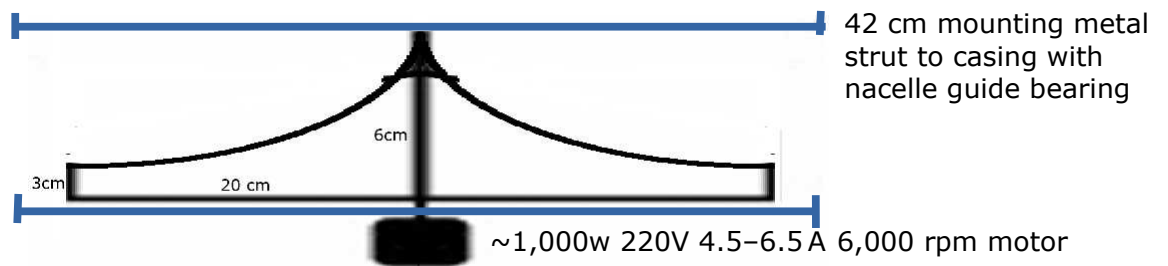

Top view mounting strut :

Metal mounting 42cm diameter strut to casing with propeller plane's topside unit having builder's option of center support nacelle guide bearing.

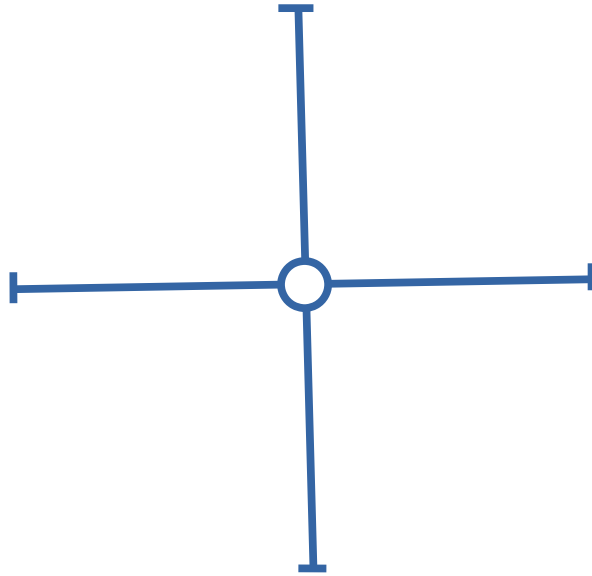

Top view :

Propeller plane rotor 4-blade baseline gap density in light weight carbon fiber fabrication diameter (40cm)  $r \approx 3\text{cm} \times 20\text{cm} \times 6\text{cm} \times 3.0\text{mm}$ .

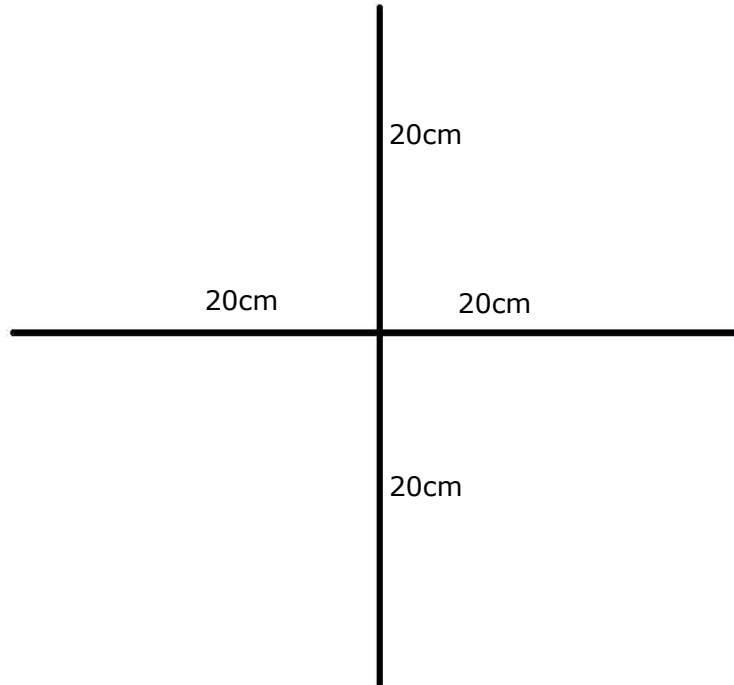

# **Spec Summary – 40 cm Rotor Test PHD MMP**

## **1. Geometry & Structure**

- **Rotor diameter:** 40 cm
- **Inner shaft:** 42 cm ID ( ducted ) 4mm thick wall
- **Outer casing:** 64 cm OD, carbon-fiber 4mm thick wall
- **Shaft length:** 100–128 cm inner, outer
- **Propeller Plane:** Carbon-fiber, 4-blade ( baseline ) alt. 8-blade ( high-density ) or 2-blade ( nominal-density )
- **Propeller Plane radius blade dimensions:** 30 mm outer height × 200 mm length × 60mm inner height × 3 mm thickness

### **Propellers pitch clockwise and counter-clockwise (inverse):**

#### **Geometry**

- **Diameter:** 400 mm (R = 200 mm)
- **Blades:** 8
- **Solidity at 0.75R:**  $\sigma \approx 0.20$
- **Airfoil:** NACA 4412-class, 12–15% t/c, moderately cambered

#### **Chord distribution**

- **0.30R:** 16 mm
- **0.50R:** 16 mm
- **0.75R:** 16 mm
- **0.95R:** 16 mm

#### **Pitch distribution**

- **Hub:** 28°
  - **0.5R:** 22°
  - **0.75R:** 17°
  - **Tip:** 14°
- 
- **Mounting:** 42 cm metal strut, reinforced hub ring

## 2. Motor & Drive

- **Motor type:** QW80BL00760-1000 High-speed BLDC with permanent-magnet rotor
- **Rating:** ~1,000 W continuous, 6,000 rpm
- **Input:** 220–240 V AC to matched BLDC driver
- **Driver output:** Controlled 3-phase PWM
- **Continuous current:** 4.5–6.5 A per motor
- **Peak current:** 10–18 A ( driver-limited )
- **Cooling:** Free airflow
- **RPM feedback:** Hall-sensor or external RPM meter, 100–500 Hz logging

## 3. Sensors & Instrumentation

- **Differential pressure sensors:**
  - Quantity: 2
  - Range:  $\pm 5$  kPa
  - Resolution:  $\leq 5$ –10 Pa
  - Sample rate: 100–500 Hz
  - Mounting: Flush taps, short tubing, upstream & downstream
  - 3.3 V sensor models
- **Absolute pressure sensor:**
  - Quantity: 1 ( bottom of shaft )
  - Range: 0–2 bar abs
  - 3.3 V sensor model
- **Thrust measurement:**
  - External load cell scale ( 5–10 kg range )
- **Electrical isolation:**
  - Separate 220 V and low-voltage wiring; shielded sensor cables

## 4. Expected Performance

- **Thrust:** 5–10 kg
- **MMP Pressure rise:**  $\pm 200$  Pa to  $\pm 400$  Pa
- **PHD Pressure rise:** -400 Pa to -800 Pa
- **Tip speed potential:**
  - 4,000 rpm  $\rightarrow$   $\sim 83.8$  m/s ( Mach  $\sim 0.24$  )
  - 6,000 rpm  $\rightarrow$   $\sim 125.7$  m/s ( Mach  $\sim 0.37$  )
- **Flow regime:** Solidity, high-pressure, low-flow static thrust

## 5. Test Procedure

- **RPM PP & P's Matrix:** 2,000  $\rightarrow$  3,000  $\rightarrow$  4,000  $\rightarrow$  5,000 rpm for 32 tests
- **Log:**  $\Delta p$  (  $2\times$  ), absolute  $p$ , RPM, thrust
- **Variants:**
  - PHD
  - MMP Forced Plane
  - 4-blade alternative vs 8-blade vs 2-blade propeller plane
- **Troubleshooting:**
  - Replace propeller plane 4-blade baseline density with high density 8-blade or 2-blade nominal density if underperforming depending on diagnostic from 4-blade tests
  - Verify pressure taps and RPM sensor alignment

## 6. Safety & Containment

- **Casing:** Designed to contain blade failure at  $\geq 8,000$  rpm with 4 mm thick two layer wall in carbon fiber / epoxy construct
- **Fasteners:** Elastic top closure with reinforced latch points
- **Electrical:** Grounded motor housings; star-ground for sensors
- **Clearances:** 1 cm radial clearance between rotors and inner shaft

Notes:

The most commonly used software for generating 3D technical illustrations and prototype-ready renditions are specialized CAD-linked illustration tools such as PTC Creo Illustrate, CorelDRAW Technical Suite (with XVL Studio 3D), Canvas X Pro, and VizEx Edit 3D, along with mainstream CAD platforms like SolidWorks, Autodesk Inventor, and CATIA that include built-in rendering/illustration modules.

Request:

**I need a full set of 3D technical illustrations and manufacturing drawings for a cylindrical propulsion prototype.**

Deliverables:

1. Parametric 3D CAD assembly model (all components).
2. Exploded 3D assembly views with callouts.
3. Section/cutaway views showing internal geometry and airflow path.
4. Fully dimensioned 2D manufacturing drawings with tolerances.
5. Instrumentation layout drawings (pressure taps, RPM meters, cable routing).
6. Optional: photorealistic renders.

All geometry and metrics are provided in the attached specification (MMP-Prototype.pdf). The illustrations must be suitable for prototype fabrication and technical review.

Stefan Y. A. Tubman